

17

MOTOCROSS AND SUPERCROSS

17.1 PROTECTIVE CLOTHING - MOTOCROSS AND SUPERCROSS

17.1.0.1 No competitor may practice, start or compete in any Motocross or Supercross competition unless wearing the following protective equipment and clothing:

17.1.1 Helmet

17.1.1.1 An approved and correctly fitting helmet which must:

- a) Carry the Standards Association of Australia "AS 1698" label; or
- b) Be approved under Rule 01.69 & 01.70 of the FIM Technical Rules [see Appendix 1].

17.1.2 Clothing

17.1.2.1 Trousers of leather or synthetic material of similar durability.

17.1.2.2 Trousers of other than leather must be non-combustible and be fitted with a lining,

17.1.2.3 A jersey which must be:

- a) Made of close knit fabric of natural or synthetic fibre, and
- b) Must be a snug fit and provide protection against abrasion to the body and arms.

17.1.3 Footwear

17.1.3.1 Boots which must be:

- a) Of recognised Motocross type,
- b) Constructed of leather, plastic or other similarly durable material, and
- c) Of a length that must at least cover $\frac{3}{4}$ of the length of the lower leg, with the rider in a racing position on the machine.

17.1.4 Gloves

17.1.4.1 Gloves of leather or other material of similar or greater durability.

17.1.5 Goggles and Visors

17.1.5.1 A competitor must, at the start of an event, be wearing goggles or a simila form of eye protection. It is strongly recommended that the competitor wear the eye protection at all times during the event. Where the competitor removes their eye protection during the course of

an event, they do so entirely at their own risk. Eye protection, including spectacles, protective goggles, helmet visors and/or 'tear-offs' must comply with the following:

- a) Eye protectors and spectacles are made of non-shattering material,
- b) Eye protectors which cause visual disturbance are not to be used,
- c) Metal or Perspex face shields are not used,
- d) Eye shades or peaks are of a flexible material.

17.1.6 Hair and Jewellery

17.1.6.1 Hair longer than shoulder length must be confined in the helmet or jacket.

17.1.6.2 Body jewellery is to be removed or securely covered with tape prior to competition.

17.1.7 Footwear in pits

17.1.7.1 Closed footwear must be worn at all times in the pit area.

17.1.8 Junior Clothing

17.1.8.1 In addition to the general requirements for clothing, Juniors must comply as follows:

- a) Protective clothing must not be loose or flapping,
- b) Synthetic or rubber boots may be worn as an alternative to leather for competitors with smaller than a size 1 foot,
- c) Commercially manufactured body armour must be worn. Soft roost protection is unacceptable.

17.2 FRAMES AND PARTS - MOTOCROSS AND SUPERCROSS

17.2.1 Solo

17.2.1.1 Hand lever protectors:

- a) Must be single mounted for Motocross and Supercross,
- b) May be double mounted on machines in club and inter-club natural terrain Motocross events.

17.2.1.2 Efficient brakes must be fitted to the front and rear wheels.

17.2.1.3 When the brake cam arm or lever is of the open or hooked type, the brake actuating

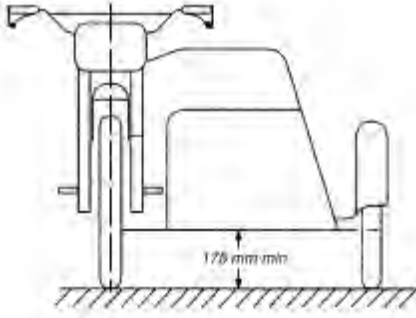

rod or cable must be secured so as to prevent accidental dislodgment.

17.2.1.4 No machine may be fitted with scoop or paddle tyres.

17.2.1.5 The handlebars must be equipped with a protection pad on the cross bar. Handlebars without a cross member must be equipped with a protection pad located in the middle of the handlebars, covering the handlebar clamps.

17.2.2 Sidecar

17.2.2.1 Wheel track measurement, taken between the longitudinal centres of the rear and sidecar wheels must be between 810mm and 1,200mm.

17.2.2.2 The minimum ground clearance must be 175mm unladen.

17.2.2.3 The maximum lean of the motorcycle at saddle height must be 50mm.

17.2.2.4 There must be no less than 4 sidecar attachment points.

17.2.2.5 The dimensions of the sidecar baseboard in plan view, taken from a line drawn no further rearwards than the lowest point of the front down-tube to the forward most point of the sidecar wheel tyre and terminating no further rearwards than a line drawn at right angles to the machine from the rearmost point of the rear tyre, must be:

- A minimum of 760mm long adjacent to the sidecar wheel,
- A minimum of 300mm width, with at least 25mm radius to all corners.

17.2.2.6 There must be no more than 50mm between baseboard and motorcycle and between baseboard and sidecar wheel. The baseboard must be arranged to prevent the passenger's feet being trapped.

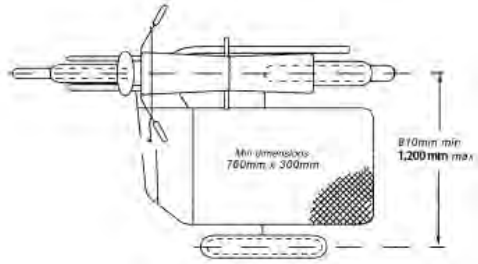

17.2.2.7 All handholds must be finished with a loop of at least 100mm.

17.2.2.8 Stirrup fitting for the passenger's feet are not permitted.

17.2.2.9 Handholds on the sidecar:

- Must not project beyond a line taken with the outer edge of the sidecar mudguard or bodywork,
- Adjacent to the nose section of the sidecar and less than 200mm from the track surface must be at an angle of at least 45° from the horizontal.

17.2.2.10 The rear end of the rear wheel mudguard must terminate not more than 65° above a horizontal line drawn through the rear wheel axle and be valenced to baseboard level on the inside.

17.2.2.11 The sidecar mudguard must cover at least 135° of the periphery of the wheel and be valenced to baseboard level on the inside.

17.2.2.12 No machine may be fitted with scoop or paddle tyres.

17.3 NOISE EMISSIONS - MOTOCROSS AND SUPERCROSS

17.3.0.1 Motocross machines must comply with noise emission tests as per GCR 12.10, however the following table should be substituted for 12.10.2.

CAPACITY	RPM
Up to 85cc	8,000
85cc to 125cc	7,000
Over 125cc up to 150cc 4-stroke	6,000
126cc to 250cc	5,000
251cc to 500cc	4,500
Over 500cc	4,000

17.4 FUEL- MOTOCROSS AND SUPERCROSS

- 17.4.0.1 Fuel for all machines must:
- Be Unleaded, and
 - Be no more than 100 RON, and
 - Contain no additives other than those added at the point of manufacture except for:
 - lubricating oil for 2-stroke engines
 - Upper cylinder lubricant for 4 stroke engines
 - Be readily available from retail petrol pumps within Australia, or
 - Be a brand of fuel homologated by MA that is compatible with the "Fuel Quality Standards Act 2000"

17.5 SENIOR CLASSES- MOTOCROSS AND SUPERCROSS

17.5.1 Machines Other Than Junior

- 17.5.1.1 The capacity classes for machines
- Other than for Junior competitions,
 - Other than Australian Championships are:

CLASS	CAPACITIES
Lite	2-stroke 100cc to 150cc Big Wheel 4-stroke 200cc to 250cc Big Wheel Wheel sizes (16" - 19" rear and 19" - 21" front)
Open	2-stroke from 165cc to 500cc 4-stroke from 255cc to 650cc
Under 19	Up to 250cc (2 or 4 stroke)

- 17.5.1.2 Sidecars.
17.5.1.3 Modern.
17.5.1.4 Pre 1985 - Note Frame and motor must be manufactured prior to 31st December 1984.

17.6 JUNIOR CLASSES- MOTOCROSS AND SUPERCROSS

- 17.6.1 50cc motorcycles are to comply with GCR 12.16.
- 17.6.2 **80cc 4-Stroke Class**
- 17.6.2.1 Machines in the 80cc 4-stroke classes must remain standard with the manufacturer's specifications with the exception of:
- Exhaust system,

- Gearing,
- Carburettor jetting,
- Plastics, and
- Handlebars.

17.7 COMPETITOR GRADING- MOTOCROSS AND SUPERCROSS

17.7.1 Senior Grades - Motocross and Supercross

- 17.7.1.1 The grades of competitors in Senior classes are:
- Pro Class,
 - Intermediate Class,
 - Clubman.

~~17.7.2 Freestyle Motocross~~

- ~~17.7.2.1 There are 2 levels of Freestyle Motocross Endorsement:~~
- ~~Freestyle Motocross,~~
 - ~~Professional Freestyle Motocross~~

17.8 COMPETITION RULES - ALL AGES AND CLASSES

17.8.1 Starting

- 17.8.1.1 Unless otherwise determined in the SR, massed starts must be used.
- 17.8.1.2 The order and position of each competitor will be at the discretion of the Promoter and will be determined on the day of the event.
- 17.8.1.3 The starting grid for all events will:
- Have not less than 1 metre space for each solo motorcycle,
 - Be in 1 straight line,
 - Allow for no more than 40 competitors.
- 17.8.1.4 The maximum number of starters must be specified in SR.
- 17.8.1.5 Unless otherwise determined in the SR, for solo events:
- Individually backward falling devices, with each gate a minimum of 500mm and a maximum of 600mm in height, must be used,
 - A rear barrier must be placed to prevent riders from moving their motorcycles no more than 600mm back from the gate.
 - Preparation on the start gate is to be confined to the area between**

the rollback barrier and gate hinge and no materials may be brought onto the start area unless directed by the starter, on the instructions from a key official

- d) No work is to be done in front of the start gate (track proper) unless directed of a key official.

17.8.1.6 Unless otherwise determined in the SR, for sidecar events, the width of the starting grid must permit a minimum of 15 machines in 1 row, with 2 metre space for each machine.

17.8.1.7 Unless otherwise determined in the SR:

- a) All competitors must be called to the start line at least 2 minutes before each start,
- b) At the end of the 2 minutes, and when the starter is ready, the starter will hold up a 15 second sign for a full 15 seconds,
- c) At the end of 15 seconds, a 5 second sign will be displayed,
- d) The gate will drop between 5 and 10 seconds after the 5 second sign is shown.

17.8.1.8 Competitors may use up to 2 starting blocks (one per side) up to a maximum of 100mm high and must be able to start in an event without additional aid while sitting on the machine.

17.8.2 No Jump Signals

17.8.2.1 Yellow flags will be waved in Motocross events to indicate immediate danger,

17.8.2.2 When yellow flags are waved, competitors must not:

- a) Jump,
- b) Overtake other competitors.

17.8.2.3 During the first lap of practice, yellow flags will be displayed stationary indicating there will be no jumping.

17.8.3 Stopping and Rerunning of Events where electronic timing is used.

17.8.3.1 Where the Steward or the Clerk of Course has stopped a race due to danger the following will apply:

- a) If no more than 2 laps of the stopped race were completed.
 - i The stopped race will be declared null and void,
 - ii The race may be rerun,

iii The rerun race will be for the full race distance,

iv The original grid positions will be used,

v The place of any machine unable to take part in the rerun race will be left vacant,

vi Machines may be repaired or replaced providing this has been approved by the Clerk of Course.

b) If more than 2 laps, but less than 75% of the race distance has been completed:

i The race may be restarted if possible, but only once,

ii The restart must occur no more than 1 hour after the race has been stopped,

iii The re-started race distance will be equal to the balance of the stopped race distance,

iv Selection of grid positions for the re-started race will be determined by the order of competitors at the finish line of the last full lap of the stopped race,

v Only competitors who have completed at least 75% of the laps completed by the leading competitor at the time of stopping will be permitted to participate in the re-started race,

vi Machines may be repaired or replaced providing this has been approved by the Clerk of Course,

vii The stopped race and any rerun will be deemed to be parts of 1 race,

viii The winner will be the competitor having the highest number of laps at the finish,

ix Where 2 or more competitors complete the same number of laps the winning order will be determined by the time taken by each to complete those laps,

x If more than 15 laps of the scheduled race distance is completed full points will be awarded,

xi If less than 75% of the scheduled 153

race distance is completed half points will be awarded.

17.8.4 Finishing

17.8.4.1 The finish line must be:

- a) Marked with a flexible post at each side of the track, and
- b) Clearly visible to the judge.

17.9 COMPETITION RULES - SUPERCROSS

17.9.1 Supercross Licence Conditions

17.9.1.1 No person may compete in a Supercross race unless they:

- a) Are at least 12 years of age,
- b) Have a current national competition licence which is endorsed under the following rules.

17.9.1.2 To be endorsed as a Supercross competitor, a person must:

- a) Use a solo machine with a capacity of at least 80cc;
- b) Attend a Supercross training school conducted by an MA accredited coach,
- c) At the conclusion of the Supercross training school, be able to competently display to the MA accredited coach the following:
 - i) Jump a double jump, which is:
 - 8 metres for 85cc riders,
 - 10 metres for 150/250cc riders,
 - ii) Jump a tabletop, which is:
 - 8-10 metres for 85cc riders,
 - 10-12 metres for 150/250cc riders,
 - iii) Ride through stutters at a competitive speed in a straight line,
 - iv) A sound knowledge of Supercross Rules and safety issues as examined by a multiple-choice questionnaire.

17.9.1.3 The coach conducting the assessment under the preceding GCR may endorse the licence of a person as a Supercross competitor. A decision to:

- a) Endorse the licence,
- b) Refuse an endorsement, or
- c) Grant an endorsement conditionally, will have the same force and effect as if it was a decision by an SCB under GCR 3.1

17.9.1.4 A person who:

- a) Has entered a Supercross competition,

- b) Has paid the entry fee for the relevant meeting,
- c) Is required to submit to an assessment under these Rules, and
- d) Fails to be endorsed as a Supercross competitor at the meeting.

is entitled to a refund of the fee.

17.9.1.5 Once endorsed for Supercross, a person retains that endorsement unless:

- a) They fail to participate in a Supercross event each year,
- b) During the course of a Supercross meeting, the Steward or Clerk of Course determines otherwise.

17.9.2 No Jump Signals

17.9.2.1 Yellow flags will be waved in Supercross events to indicate immediate danger.

17.9.2.2 When yellow flags are waved competitors must not:

- a) Jump,
- b) Overtake other competitors, at the set of jumps where the yellow flags are waved.

17.9.2.3 The penalties for breaching this GCR are:

- a) First offence, relegation of 3 places and up to a \$500 fine,
- b) Subsequent offences in the same year, exclusion and \$500 fine.

17.9.3 Warm Up Lap

17.9.3.1 During the first lap of any practice yellow flags are to be displayed stationary to indicate there will be no jumping.

17.10 COMPETITION RULES - FREESTYLE MOTOCROSS

17.10.1 Freestyle Motocross Licence Conditions

17.10.1.1 No person may participate in Freestyle Motocross unless they:

- a) Are at least 16 years of age, and
- b) Have a current MA Senior National competition licence which is endorsed under the following Rules.

17.10.1.2 To be endorsed as a Freestyle Motocross competitor, a person must use a solo machine with a capacity of at least 125cc.

17.10.1.3 To gain a Freestyle Motocross endorsement a rider must:

- a) Have a MA Senior National Licence

- and be endorsed for Supercross;
- b) Attend a Freestyle Motocross Training School conducted by an accredited Freestyle Motocross ~~Coach~~ **Assessor**;
- c) Successfully complete the MA competency assessment;
- d) ~~A rider with this level of endorsement can only perform under the following conditions:~~
 - i) ~~Jump with a minimum take-off and landing zone of 25m (distance is from front wheel to base of ramp);~~
 - ii) ~~Jump a maximum distance of 10m (distance is from end of jump ramp to start of landing ramp).~~

17.10.1.4 To gain a Professional Freestyle Motocross endorsement a rider must:

- a) ~~Have a MA Senior National Licence;~~
- b) ~~Be endorsed for Freestyle Motocross;~~
- c) ~~Perform at a minimum of 6 MA permitted events with a Freestyle Motocross Endorsement;~~
- d) ~~Consistently demonstrate an ability to jump a minimum distance of 23m with a run-up and run-off of 20m or less;~~
- e) ~~Successfully complete the MA competency assessment for Professional Freestyle Motocross conducted by approved coach.~~

17.10.1.5 The Endorsing ~~each~~ **Assessor** must:

- a) Be identified and approved by the MA Motocross Commission to endorse Freestyle Motocross;
- b) Obtain a ~~Coaching~~ Permit from the RCB in which the assessment is taking place.

17.11 COMPETITION RULES - FAST 50s

17.11.1 Fast 50s - Protective Equipment

17.11.1.1 As per GCR 16.1 except 16.1.3 which is replaced by:

17.11.1.2 Footwear which must be:

- a) Constructed of leather, plastic or other similarly durable material; and
- b) Of a length that must at least cover the ankle, with the rider in a racing position on the machine.

17.11.2 Fast 50s - Classes of Competition

17.11.2.1 Senior Classes- 16 years of age and over:

- a) Stock 50cc,
- b) Limited 50cc,
- c) Mod 88cc,
- d) Mod 110cc,
- e) 110 Big Wheel Mid Size,
- f) Super Mod,
- g) 125cc,
- h) Open Outlaw,
- i) Women,
- j) Vets over 30 years of age,
- k) Seniors. Pro Class,
- l) Seniors. Amateur Class.

17.11.2.2 Junior Classes- 12 to under 16 years:

- a) Stock 50cc.
- b) Limited 50cc.
- c) Mod 88cc.
- d) Mod 110cc.

17.11.3 Fast 50s - Approved Modifications

17.11.3.1 The following may be modified:

- a) Cosmetic changes, including but not limited to:
 - i) Colour,
 - ii) Handle bars,
 - iii) Graphics,
 - iv) Foot pegs,
 - v) Gear levers,
 - vi) Heavy duty rims,
- b) Air filters may be replaced with after-market products,
- c) Heavy duty springs and front and rear shock absorbers,
- d) Gearing, limited to sprockets,
- e) Exhaust pipes,
- f) After market camshaft and timing chain.
- g) Stock 50cc machines in both senior and junior classes may strengthen the frame / chassis.
- h) All machines, except those in Stock 50cc class in either senior or junior class, may use:
 - i) After-market frames / chassis,
 - ii) After-market forks,
 - iii) Rear shocks,
 - iv) Heavy duty clutches,
 - v) CDI units,
 - vi) After market close ratio gearbox.

17.11.3.2

Modifications to limited specific classes of machines as per table on following page, unless otherwise specified in the SR:

CLASS	FRONT WHEEL (inches)	REAR WHEEL (inches)	HEAD INCL PORTING AND GRINDING	BARREL AND CARBURETTOR	INNER ROTOR	AUTO/ MAN	STD OEM CRANK CASE
Stock 50cc Snr	10	10	N	std 50cc	N	A	Y
Stock 50cc Jnr	10	10	N	std 50cc	N	A	Y
Limited 50cc to 90cc Snr	12	10	N	90cc	N	A	Y
Limited 50cc to 90cc Jnr	12	10	N	90cc	N	A	Y
Mod 88cc - Snr	12	10	Y	88cc	Y	A	Y
Mod 88cc - Jnr	12	10	Y	88cc	Y	A	Y
Mod 110cc Snr	12	12	Y	110cc	Y	A	Y
Mod 110cc Jnr	12	12	Y	110cc	Y	A	Y
110cc Big Wheel Mid Size	14	12	Y	110cc	Y	A	Y
Super Mod	12	12	Y	124cc	Y	A	Y
125cc	12	12	Y	125cc	Y	Either	Y
Open Outlaw	14	12	Y	150cc	Y	Either	N
Women / Vets	14	12	Y	150cc	Y	Either	N
Seniors. Pro Class	Open	Open	Y	125cc	Y	Either	N
Seniors. Amateur Class	Open	Open	Y	125cc	Y	Either	N

17.11.4 Fast 50s - Capacity Tolerances

17.11.4.1 The actual engine capacity of a machine competing in a capacity class may not exceed the prescribed capacity.

17.11.5 Fast 50s - Competition Rules

17.11.5.1 All machines must be an open cradle frame unless specified in SR; and

17.11.5.2 All entrants and competitors declare that by entering an event, that their machine / machines are suitable for the class in which they are entered.

17.11.5.3 All entrants and competitors declare that they have satisfied themselves as to the suitability of their machine for the purpose of racing.

17.11.5.4 **GCR 12.8.4** (side stands) does not apply to this discipline.

17.11.5.5 **GCR 17.6.2** (80cc 4-Stroke Class) does not apply to this discipline.

17.11.5.6 **GCR 12.16.0.3** does not apply to this discipline.

17.11.6 Fast 50s - Starting

17.11.6.1 **GCR 17.8.1.3 c** does not apply to this discipline as there can be no more than 20 competitors on the track at any time. This number may be lower than 20 depending on the track conditions.

17.11.6.2 Starting as per **17.8.1**, excluding **17.8.1.3 c**.

17.12 AUSTRALIAN MOTOCROSS CHAMPIONSHIPS

17.12.1 Senior Championship Classes

CLASS	CAPACITY 2-STROKE	CAPACITY 4-STROKE
Pro-Lites	100cc-150cc	200cc-250cc
Pro-Open	156cc to 250cc	251cc to 450cc
Under 19	up to 250cc	up to 250cc

17.12.1.1 The under 19 Australian Motocross Championship will be for riders from 15 years to under 19 years. A rider's age on 1st January will determine their age for the Championship. 15 year olds may participate provided they meet the following criteria:

- Satisfy their SCB of their competence,
- Obtain a licence endorsement for AMXC under 19,
- State legislation will override these rules where applicable.

17.12.2 Riders who turn 15 before the first round of the Under 19 Australian Motocross Championship may place an entry for the series provided they meet the criteria above. If they do they will be deemed to have moved up an age group.

17.12.3 15 year olds will compete with an endorsed MA National Junior licence. Riders who turn sixteen during the series can continue in other relevant competition as a junior, they are competing in the Championship as Juniors.

17.12.2 Format

17.12.2.1 The Championship format will be determined by the Motocross Commission and published in SR.

17.12.3 Practice and Qualifying

17.12.3.1 As directed in the SR, any heats and qualifiers are to be held on the day of the meeting.

17.12.3.2 Timed practice for any event may be held either on Saturday afternoon or Sunday morning.

17.12.3.3 All grid positions will be determined by qualifying times.

17.12.3.4 No competitor may enter the track for practicing on any of the 8 days immediately preceding the event other than the official press day..

17.12.3.5 The 10 competitors leading the Championship prior to each subsequent round will qualify for the round.

17.12.3.6 The remaining 30 competitors shall lodge an Expression of Interest for the series as per the SR.

17.12.3.7 U19 Championship

All competitors eligible for the U19 Championship in their first year of senior national competition must compete in the U19 years Championship. Exception may be granted by the MX Commission where a rider has been senior at State level for a period of time and can demonstrate his or her ability at State open events, or where exceptional circumstance (ie rider size) is more suited to the Open class. On having moved to Pro-Lite or Pro-Open events except as a wildcard entry then a competitor will no longer be eligible for the U19 years Championship series. This rule will be effective from January 1, 2009.

17.12.4 The Event

17.12.4.1 For each class, a round will consist of 2 races.

17.12.4.2 The duration of each race will be specified in SR.

17.12.4.3 The races must be conducted on the same day with a minimum of 15 and a maximum of 40 competitors in each race.

17.12.4.4 Each competitor may compete on a substitute machine, provided that the competitor must notify the Clerk of Course before commencement of the race in which the substitution is to be made.

17.12.5 Allocation of Numbers

17.12.5.1 The No 1 numberplate in each class will be allocated to the winner of the previous year's Championship.

a) The recipient of this number can choose not to use No.1, but instead use their career number. No.1, or that competitor's career number will not be used by any other competitor in that class.

b) For the first round of each Championship the previous years Champion will carry a numberplate with red background and white figures.

c) The leader of each championship after the first round will use the numberplate with red background & white figures.

17.12.5.2 Pro Lite and Pro Open numbers after No.1 will be allocated as career numbers by the MX Commission to a maximum of 20 riders using the following method:

a) ~~For 2009~~ A competitor's overall Championship results from the previous ~~three~~ year's Motocross & Supercross Championships will be used to decide the order in which they pick their career number, which is determined by:

b) Aggregated Championship points awarded in both competitions and ,

c) Aggregating them as a percentage as calculated by the Motocross Commission of MA.

~~d) For 2010 and beyond the method used to determine the order in which available career numbers are chosen, may be the same as 17.12.5.2 (a),(b) & (c), with the results from the previous year only used.~~

e) Numbers 2 to 10 can only be chosen as career numbers by competitors who finished in the top ten of either Lites or Open Championships. The first three from the U19 Championship may also choose a 2 to 10 number if available.

f) Competitors who do not fit the above criteria may make an application to the Motocross Commission of MA for special

consideration for a career number. The criteria for this would be recognised International riders, previous Champions, etc.

17.12.5.3 If 2 or more competitors aggregate the same number of points, preference will be given to:

- a) Competitor who competed in the most championship events, then
- b) The competitor who achieved the highest number of points at the last championship round they both competed at.

17.12.5.4 For competitors to retain their career number they must compete in at least one round each year of either the MX or SX Championships, and score a minimum of 50 points in total of both Championships combined. Exemptions to be considered for injury, or international competitors.

17.12.5.5 No competitor may compete unless wearing the machine identification number on their back in contrasting colours and with a minimum size of 125mm height and 20mm width of stroke.

17.12.6 Scoring for Each Race

PLACE	POINTS	PLACE	POINTS
1	25	11	10
2	22	12	9
3	20	13	8
4	18	14	7
5	16	15	6
6	15	16	5
7	14	17	4
8	13	18	3
9	12	19	2
10	11	20	1

17.13 AUSTRALIAN JUNIOR MOTOCROSS CHAMPIONSHIPS

17.13.1 Format

17.13.1.1 The format of the championships will be:

CLASSES	FORMAT
Under 80cc	7 minutes + 1 lap
Sidecars	7 minutes + 1 lap
80cc and over	10 minutes + 1 lap

17.13.1.2 At least 5 practice laps must be offered to riders prior to the commencement of racing.

17.13.1.3 There will be a minimum of 5 legs per

class.

17.13.1.4 If heats and finals are required:

- a) Heats will be 3 legs per class, with heats to be mixed, and
- b) Finals will be 3 legs per class.

17.13.2 Allocation of Numbers

17.13.2.1 A competitor's racing number will be determined as follows:

- a) The first digit will be the first digit of the postcode for the competitor's state of residency, except the Northern Territory, which will be 1,
- b) The remainder of the number will be at the discretion of the RCB.

17.13.3 Venues

17.13.3.1 Venues used for Australian Junior Motocross Championships will be closed to competitors for a minimum of 21 days prior to the event.

17.13.4 Interstate Challenge

17.13.4.1 Format - Each state is to choose a team of eight (8) junior competitors from a minimum of four (4) different classes to compete for the Interstate Cup Challenge. Each competitor must be entered for the Australian Junior Motocross Championship, prior to the



RINGMASTER IMAGES
CUSTOM MX GRAPHICS
STICKERS & DECALS

Unit 17/63-71 Bayfield Rd East,
 Bayswater Nth VIC 3153
 Ph: 03 9720 2223 Fax: 03 9720 2234
 Email: enquiries@ringmasterimages.com.au
www.ringmasterimages.com.au
www.facebook.com/ringmasterimages
www.myspace.com/ringmasterimages
www.twitter.com/ringmastermotocross

closing date. Team members must be named and the Race Secretary be informed by the end of practice.

17.13.4.2 Scoring - Each competitor will be scored as per GCR 12.14.0.1 within their own class. At the end of the Australian Junior Motocross Championship the highest point scoring six (6) team members from each state, will have their final placing re-scored using 12.14.01 (table) to give an overall score. The State with the highest overall team score will be deemed the winner of the Interstate Cup Challenge.

17.13.4.3 Awards - A Perpetual Trophy will be awarded to the winning State, with each member of the team receiving a participation memento.

17.14 AUSTRALIAN SUPERCROSS CHAMPIONSHIP

17.14.1 Championship Classes

CLASS	CAPACITY 2-STROKE	CAPACITY 4-STROKE
SX-Lites	100cc-150cc	200cc-250cc
SX-Open	156cc-250cc	251cc to 450cc

17.14.2 Format

17.14.2.1 The format for both classes of the championships will be as determined by the Motocross and Supercross Commission and published in SR.

17.14.3 Allocation of Numbers

17.14.3.1 The No 1 numberplate in each class will be allocated to the winner of the previous year's Championship.

a) The recipient of this number can choose not to use No.1, but instead use their career number. No.1, or that competitor's career number will not be used by any other competitor in that class.

b) For the first round of each Championship the previous years Champion will carry a numberplate with red background and white figures.

c) The leader of each championship after the first round will use the numberplate with red background & white figures.

17.14.3.2 Pro Lite and Pro Open numbers after No.1 will be allocated as career numbers by the MX Commission to a maximum of

20 riders using the following method:

a) For ~~2009~~ A competitor's overall Championship results from the previous ~~three~~ year's Motocross & Supercross Championships will be used to decide the order in which they pick their career number, which is determined by:

b) Aggregated Championship points awarded in both competitions and ,

c) Aggregating them as a percentage as calculated by the Motocross Commission of MA.

~~d) For 2010 and beyond the method used to determine the order in which available career numbers are chosen, may be the same as 17.12.5.2 (a), (b) & (c), with the results from the previous year only used.~~

e) Numbers 2 to 10 can only be chosen as career numbers by competitors who finished in the top ten of either Lites or Open Championships. The first three from the U19 Championship may also choose a 2 to 10 number if available.

f) Competitors who do not fit the above criteria may make an application to the Motocross Commission of MA for special consideration for a career number. The criteria for this would be recognised International riders, previous Champions, etc.

17.14.3.3 If 2 or more competitors aggregate the same number of points, preference will be given to:

a) Competitor who competed in the most championship events, then

b) The competitor who achieved the highest number of points at the last championship round they both competed at.

17.14.3.4 For competitors to retain their career number they must compete in at least one round each year of either the MX or SX Championships, and score a minimum of 50 points in total of both Championships combined. Exemptions to be considered for injury, or international competitors.

17.14.3.5 No competitor may compete unless wearing the machine identification number on their back in contrasting colours and with a minimum size of 125mm height and 20mm width of stroke.

17.14.4 Qualifying

17.14.4.1 Conditions of qualifying must be stipulated in the SR.

17.14.5 Grid Positions.

17.14.5.1 Grid selection will be determined by qualifying times.

17.14.6 Practice & Timed Qualifying

17.14.6.1 Practice for championship events must be:

- a) Outdoor events - minimum 8 minutes for first session and minimum 10 minutes for second session,

17.14.6.2 If the track is altered during the course of the meeting, at least 1 inspection lap must be offered to all qualified competitors.

17.14.7 Points Allocation

17.14.7.1 For events which have a minimum of 10 start gates points will be allocated in accordance with the previous GCR.

17.14.7.2 For events which have fewer than 10 start gates, points will be allocated to finishers in the Final and Last Chance Qualifier on a descending basis.

PLACE	POINTS	PLACE	POINTS
1	25	11	10
2	22	12	9
3	20	13	8
4	18	14	7
5	16	15	6
6	15	16	5
7	14	17	4
8	13	18	3
9	12	19	2
10	11	20	1

17.14.7.3 If a tie on points occurs for any position in the championship, the tying competitor who has the greatest number of higher placings will be awarded the position.



Australian Government

Australian Sports
Anti-Doping Authority

IT'S YOUR BODY IT'S YOUR RESPONSIBILITY

A POLICY OF STRICT LIABILITY APPLIES IN SPORT

**Athletes must ensure that any substance
they are using is permitted in sport.**

Call us before we call on you

ANTI-DOPING HOTLINE **1800 020 506**
WEBSITE www.asada.gov.au